

# ENERGY DEMAND AND CARBON FOOTPRINT OF BLEACHING CHEMICALS



**Alexis Métais**  
Pulp & Paper Key Account Manager  
Xylem, alexis.metais@xylem.com

## Abstract:

Energy prices strongly increased in 2022 and may not stabilize quickly. It leads to additional challenges in meeting all at once competitive pulp bleaching costs and global targets on reduction of GHG emissions. The present paper intends reviewing energy demand for production of the main chemicals involved in bleaching of chemical pulp such as oxygen, ozone, chlorine dioxide and hydrogen peroxide as well the chemical precursors needed. Once done in a first part, carbon footprint will be assessed considering the influence of different national grids to help pulp producers and the local regulation authorities.

**Keywords:** Energy, Electricity, Carbon footprint, Bleaching, Ozone

## 1. Introduction:

Energy prices strongly increased in 2022 and may not stabilize quickly. It leads to additional challenges in meeting all at once competitive pulp bleaching costs and global targets on reduction of GHG (Greenhouse Gas) emissions. The present paper intends reviewing in a first part energy demand for production of the main chemicals involved in bleaching of chemical pulp such as oxygen, ozone, chlorine dioxide and hydrogen peroxide as well the chemical precursors needed. Then carbon footprint will be assessed considering the influence of different national grids to help pulp producers and the local regulation authorities.

## I Bleaching Chemicals Supply

Lignin structures including conjugated double bonds such as carbonyl groups (C=O), ethylenic groups (C=C) and aromatic rings are the main chromophores to be removed in the bleach plant. Different bleaching chemicals are involved in modern pulp bleaching such as oxygen, ozone, chlorine dioxide and hydrogen peroxide. Table 1 shows with which chemical structures they react.

Olefinic and aromatic groups	Free phenolic group and double bonds	Carbonyl groups including quinones
Cl <sub>2</sub>	ClO <sub>2</sub>	ClOH
O <sub>3</sub>	O <sub>2</sub>	H <sub>2</sub> O <sub>2</sub>

Table 1. Bleaching Chemicals and their Reactivity Towards Lignin Structures [1]

Considering the above table, it appears a bleaching sequence combining ozone, chlorine dioxide and hydrogen peroxide is able removing more chromophores and chromogens than any standard ECF bleaching implementing only chlorine dioxide and hydrogen peroxide. Z-ECF bleaching allows for the highest brightness and the lowest lignin content.

Figure 1 shows the standard scheme of bleaching chemical supply. Oxygen, ozone and chlorine dioxide are produced at site while other chemicals are shipped to the pulp mill.

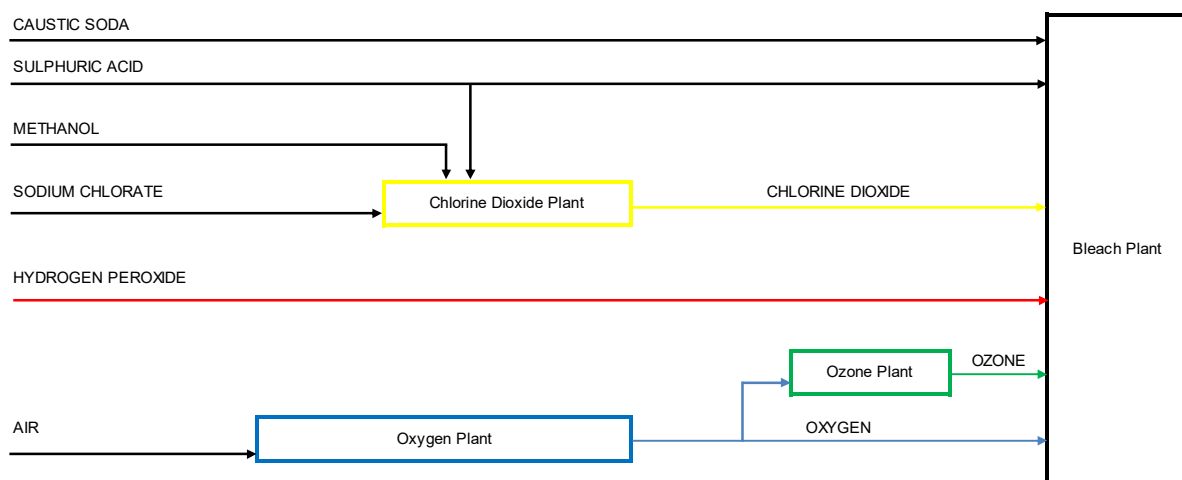

Figure 1: Bleaching Chemicals Supply Today

## II Electricity Demand for Bleaching Chemicals Production

### II.1 Oxygen

Oxygen suppliers usually supply oxygen demands below 20 t/d with liquid oxygen. An oxygen plant is installed at site for higher oxygen demands: with the Vacuum Swing Adsorption (VSA) technology up to 100 t/d and with a cryogenic plant if above 100 t/d. So, most of the pulp mills produce oxygen at site with the VSA process.

Air is compressed and then goes through a molecular sieve vessel where nitrogen is adsorbed so that typically a 93% pure oxygen stream is obtained (the remaining being 4% argon and 3% nitrogen). When the molecular sieve is saturated with nitrogen, air flows to a second vessel while a vacuum pump pulls nitrogen out of the first vessel.

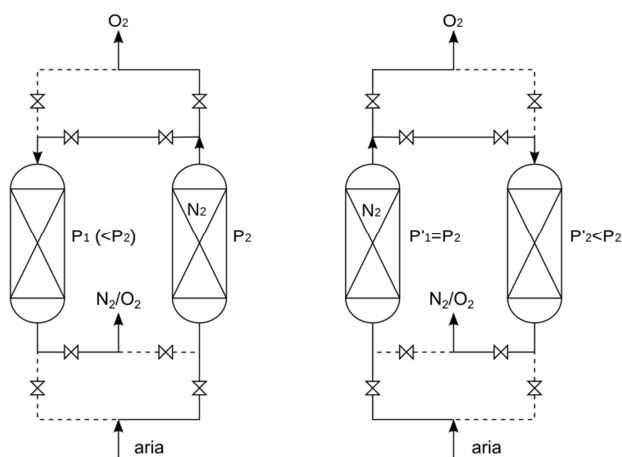

Figure 2: VSA Process

Production of 1 kg oxygen requires 0.3 kWh and air.

### II.2 Ozone

Ozone generation is a pure onsite technology: there is neither transport nor storage of hazardous chemical precursors. Ozone ( $O_3$ ) is a molecule consisting in three oxygen atoms, formed by a silent electric discharge in an oxygen stream ( $O_2$ ). For pulp bleaching, the ozone gas is produced at 12% concentration by weight in an oxygen flow at a minimal 90% purity.

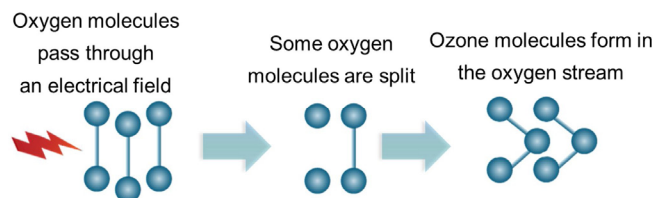

Figure 3: Ozone Generation Principle

Production of 1 kg ozone at 12% by weight requires:

- 8.3 kg oxygen
- 10 kWh

As stated above, production of 1 kg oxygen requires 0.3 kWh and air. So, production of 1 kg ozone requires 12.5 kWh.

### II.3 Chlorine Dioxide

Chlorine dioxide is, like ozone, an unstable chemical and must be produced at site. The dominant approach is to manufacture chlorine dioxide from sodium chlorate ( $NaClO_3$ ) and a reducing agent (mainly methanol, sometimes hydrogen peroxide).

Production of 1 kg chlorine dioxide requires [2]:

- 1.65 kg  $NaClO_3$  / kg  $ClO_2$
- 0.17 kg  $CH_3OH$
- 1 kg  $H_2SO_4$  / kg  $ClO_2$
- 0.13 kWh / kg  $ClO_2$

Chemical precursors such as sodium chlorate, methanol and hydrochloric acid are purchased outside of the mill.

Sodium chlorate generation consists in three main steps. First sodium chloride (NaCl) is dissolved in water and the resulting brine is purified. Then brine is electrolyzed at near neutral pH and minimum 70°C temperature. Sodium hydroxide, hydrochloric acid and catalytic amounts of sodium dichromate are used during electrolysis. The third and final step consists in sodium chlorate crystallization.

The overall reaction is  $\text{NaCl} + 3\text{H}_2\text{O} \rightarrow \text{NaClO}_3 + 3\text{H}_2$  and requires 5.2 kWh per kg of sodium chlorate [3]. So, production of 1 kg  $\text{ClO}_2$  requires  $1.65 \text{ kgNaClO}_3 \times 5.2 \text{ kWh/kgNaClO}_3 = 8.6$  kWh of outsourced electricity.

## II.4 Hydrogen Peroxide

Hydrogen peroxide is produced through the alkyanthraquinone oxidation process. Alkyanthraquinone is first hydrogenated and then oxidized with oxygen, from air, to yield hydrogen peroxide and alkyanthraquinone back.

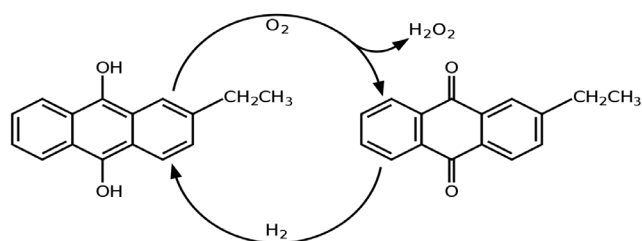

Figure 4: AQ Cycle

Production of 1 kg hydrogen peroxide requires (almost) only 1 kWh, hydrogen and deionized water.

Hydrogen is produced at 76% from natural gas, 22% from coal and at 2% through water electrolysis. The dominant process is steam methane reforming where methane reacts with steam under 20-30 bar and at 800-900°C. Methane is both a fuel (at 30-40%) and a feedstock (at 60-70%) [4].

Overall reaction is  $\text{CH}_4 + 2\text{H}_2\text{O} (+\text{heat}) \rightarrow \text{CO}_2 + 4\text{H}_2$ .

## II. 5 Electricity Demand for Z-ECF and ECF Bleaching

Standard bleaching sequences for hardwood bleaching are Z/D-Eop-D and D-Eop-D-D. The following table shows typical bleaching chemicals consumptions.

Bleaching sequence	Z/D-Eop-D	D-Eop-D-D
$\text{ClO}_2$ , kg/adt	7.2	14
$\text{O}_3$ , kg/adt	4	0
$\text{H}_2\text{O}_2$ , kg/adt	3	3

Table 2: Bleaching Chemicals Consumption for Hardwood Kraft Pulp Bleaching [5]

Onsite electricity consumption is obtained considering bleaching chemicals consumption and electricity demand for  $\text{O}_3$  and  $\text{ClO}_2$  production.

Bleaching sequence	Z/D-Eop-D	D-Eop-D-D
$\text{ClO}_2$ , kWh/adt	0.9	1.8
$\text{O}_3$ , kWh/adt	50	0
$\text{H}_2\text{O}_2$ , kWh/adt	0	0

Table 3: Onsite Consumption of Electricity (Green Electricity from Black Liquor)

Outsourced electricity consumption is obtained considering bleaching chemicals consumption and electricity demand for  $\text{NaClO}_3$  and  $\text{H}_2\text{O}_2$  production. It is  $120.4 - 61.9 = 58.5$  kWh/adt more that need to be outsourced to external electricity producers if operating an ECF bleaching sequence.

Bleaching Sequence	Z/D-Eop-D	D-Eop-D-D
$\text{ClO}_2$ , kWh/adt	61.9	120.4
$\text{O}_3$ , kWh/adt	0	0
$\text{H}_2\text{O}_2$ , kWh/adt	3	3

Table 4: Outsourced Consumption of Electricity

Total electricity consumption is in the same range, though 7.5% lower for Z-ECF than for conventional ECF (115.8 kWh/adt for Z-ECF vs. 125.2 kWh/adt for ECF) The gap would become more important if considering mining, producing, shipping and storing chemical precursors (such as sodium chloride, sodium chlorate, methanol, etc.). It is no surprise but only a confirmation as energy converts into costs: it confirms the numerous results showing lower bleaching chemicals cost for Z-ECF than for conventional ECF [5, 6, 7, 8].

## III Carbon Footprint

### III.1 Green Manufacturing

Green manufacturing is possible if using electrical power generated with low GHG emissions such as hydropower, solar panels, windmills, nuclear plants and biomass. For example, it can be said green manufacturing is done in Sweden where electricity is produced from hydropower at 50% and nuclear power at 36% and in France where electricity is produced from nuclear power at 71% and at 11% from hydropower.

In comparison sustainable production in Germany, the USA and India is more challenging as electricity is produced respectively from coal at 30% and natural gas at 10%, from coal at 22% and natural gas at 32%, from coal at 50% and natural gas at 6%.

Bleached pulp mills use biomass by harvesting carbon stored in the trees to produce pulp and energy from a single raw material. Electricity produced from sustainably managed forests can be considered as green electricity with 0 carbon footprint.

### III.2 Bleaching Chemicals Production vs Electricity Sale

Modern pulp mills produce two times more electricity than needed at site and electricity sales account for significant amounts of their revenues. But would selling electricity erase cost benefits of Z-ECF bleaching? It is not an easy question to answer but at least a publication is available on that topic. AFRY published a study [9] looking at the case of a 500,000 adt/y dissolving pulp mill with different bleaching sequences. Considering sale of electricity and cost of bleaching chemicals they found out in place of our that Z-TCF was the most profitable choice, followed by Z-ECF and standard ECF being the less beneficial option.

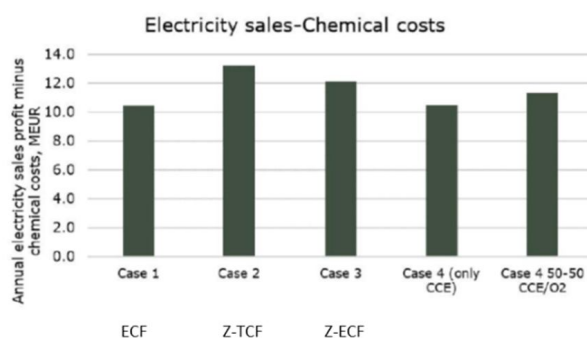

Figure 5: Annual Profits considering Electricity Sales and Bleaching Chemicals Cost [9]

### III.4 Green Bleaching Chemicals

A chemical can be considered as green if its production and use have only very little impact on the environment. Chlorine dioxide, even in the optimal case where sodium chlorate would be produced from green electricity, cannot qualify for that definition. Modern technology for chlorine dioxide generation still produces minor amounts of hazardous by-products such as chlorine, dioxins and furans [14] and chlorine, further formed during the chlorine dioxide bleaching process itself, produces AOX.

Oxygen-based chemicals such as oxygen, ozone and hydrogen peroxide do not face that drawback. As of today, only 2 bleaching chemicals can be considered as green: oxygen and ozone, both produced from air and green electricity.

Hydrogen peroxide most of the time do not currently qualify as a green chemical. Indeed, hydrogen peroxide is mainly produced from natural gas, i.e. a fossil resource. It can, or more precisely it will, be a green chemical thanks to the ongoing improvements in technology of industrial water electrolyzers (also called hydrogen generators). But it will take years before reaching that milestone.

### Conclusions

Choice of the bleaching sequence strongly impacts carbon footprint of bleached pulp production. Z-ECF proves to limit the overall climate change impact of bleached pulp production already with a limited study not addressing shipments and storage of sodium chlorate as well as other aspects of bleaching chemicals sourcing.

Pulp mills produce more green electricity than they consume internally. The choice of Z-ECF bleaching allows for all at once:

- reducing carbon footprint of bleached pulp production
- increasing profits obtained from pulp and electricity sales
- operating more independently from market variations
- benefiting of well-proven environmental benefits of ozone bleaching with lower effluent flow, COD, AOX and color loads

In the future the following bleaching chemicals supply will even be considered to produce all the main bleaching chemicals from green electricity, air and water.

### III.3 GHG Emissions

GHG emissions depend on carbon emissions of national grids. For example, electricity production emits 110 gCO<sub>2e</sub>/kWh in Canada [10], 549 gCO<sub>2e</sub>/kWh in China [11], 67 gCO<sub>2e</sub>/kWh in France [12], 402 gCO<sub>2e</sub>/kWh in Germany [12], 663 gCO<sub>2e</sub>/kWh in India [11] and 387 gCO<sub>2e</sub>/kWh in the USA [13].

In the specific case of hydrogen peroxide where methane is used both as a fuel and raw material, it is considered today that in average 10 tons of carbon dioxide are emitted per ton of hydrogen produced from natural gas [4]. So, using 1 kg of H<sub>2</sub>O<sub>2</sub> emits a minimum of 600 gCO<sub>2</sub> if considering only natural gas.

Because 58.5 kWh are outsourced to external electricity producers if operating an ECF bleaching sequence, the choice of Z-ECF allows for, depending on the national grid, reducing GHG emissions for example by 3.9 kgCO<sub>2e</sub>/adt in France, 22.6 kgCO<sub>2e</sub>/adt in the USA and 38.8 kgCO<sub>2e</sub>/adt in India.

	Canada	China	France	Germany	India	USA
Z-ECF	ref	Ref	ref	ref	ref	Ref
ECF, gCO <sub>2e</sub> /adt	+6,435	+32,116	+3,919	+23,517	+38,785	+22,639

Table 6: GHG Emissions Depending on the Bleaching Sequence

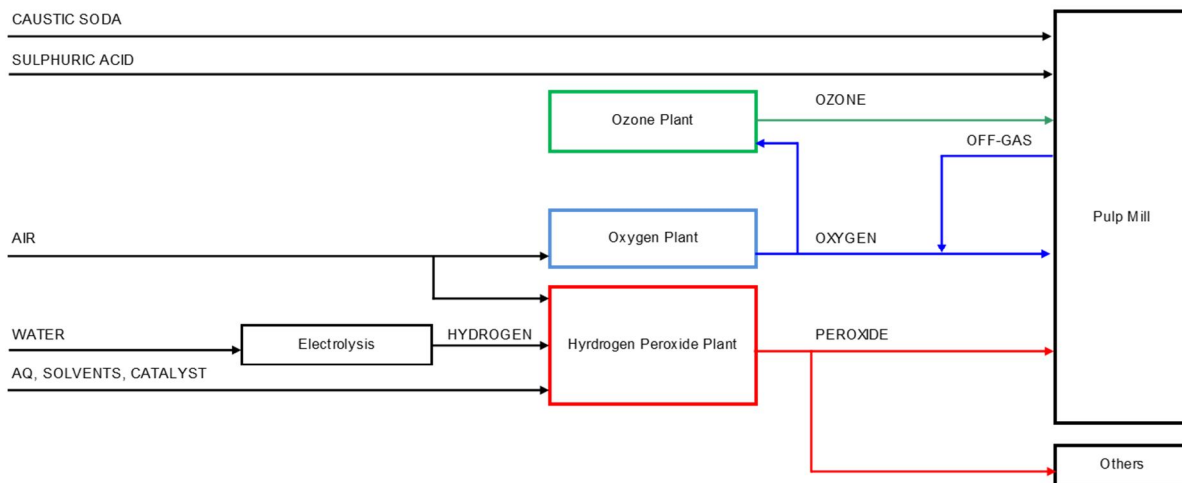

Figure 6: Bleaching Chemicals Supply in the Future?

## REFERENCES

- Lachenal, D. Muguet, M. "Degradation of Residual Lignin in Kraft Pulp with Ozone Application to Bleaching", Proceedings of the International Symposium of Wood and Pulping Conference, pp 107-112, Melbourne, Australia, April 28, 1991
- Pelin, K. "Using a Benchmarking Perspective to Ensure Chlorine Dioxide Availability and Competitiveness", Proceedings of the International Pulp Bleaching Conference, Portland, OR, USA, October 5-7, 2011
- St. Pierre, M. "Sodium Chlorate Plant, Brandon, Manitoba", Presentation to the Public Utilities Board, February 1, 2018, available at <http://www.pubmanitoba.ca/v1/proceedings-decisions/appl-current/pubs/2017%20mh%20gra/presenters/chemtrade-%20michael%20st.%20pierre%20presentation%20to%20pub%202018-02-01.pdf>
- IEA, "The Future of Hydrogen", (2019)
- Métais, A. Germer, E. "Ozone Bleaching Economics", Proceedings of the PaperWeek Conference, Montréal, Canada, February 4-6, 2019
- Lindström, L.-Å, Larsson, P.-E., "Fiberlines for Bleached Eucalyptus Kraft Pulps", Proceeding of the International Colloquium on Eucalyptus Pulp, Viçosa, Brazil, September 4-5, 2003
- Stål, C. M. Wennerström, M. "ZeTrac Technology", Proceedings of the Estrategias a Corto y Medio Plazo en el Campo de la Madera, Pulpeado y Blanqueo, Sevilla, Spain, September 12, 2008
- Guzev, D., Sovremennaya Tendentsiya Razvitiya Tekhnologiy Proizvodstva Belonoy Tsellyulozy, Webinar «Sovremennoye Sostoyaniye i Perspektivy TsBP», May 25, 2021
- <https://afry.com/en/insight/assessing-industrial-production-different-prehydrolysis-kraft-dissolving-pulp-grades> retrieved on 13 February 2023
- <https://www.cer-rec.gc.ca/en/data-analysis/energy-markets/provincial-territorial-energy-profiles/provincial-territorial-energy-profiles-canada.html> retrieved on 13 February 2023
- <https://ember-climate.org/insights/research/global-electricity-review-2022/> retrieved on 13 February 2023
- [https://www.eea.europa.eu/data-and-maps/daviz/co2-emission-intensity-12/#tab-chart\\_2](https://www.eea.europa.eu/data-and-maps/daviz/co2-emission-intensity-12/#tab-chart_2) retrieved on 13 February 2023
- <https://www.eia.gov/tools/faqs/faq.php?id=74&t=11#:~:text=In%202020%2C%20total%20U.S.%20electricity,CO2%20emissions%20per%20kWh> retrieved on 13 February 2023
- Pelin K., Perrson F., Stolz E., US Patent 2010/0055027 Production of Chlorine Dioxide, (2010).